

CSM 550

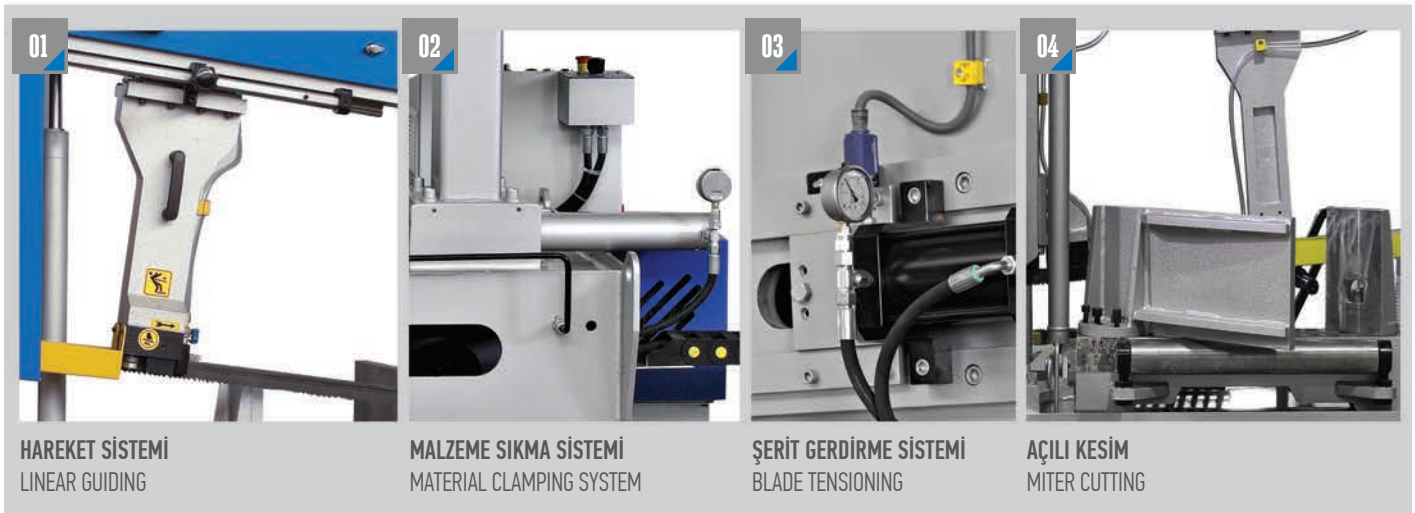

YARI OTOMATİK HİDROLİK SÜTUNLU TESTERE TEZGAHI SEMI AUTOMATIC DOUBLE COLUMN HYDRAULIC BANDSAW MACHINE



ÖLÇÜLER DIMENSIONS

SÜTUNLU MODELLER DOUBLE COLUMN TYPES

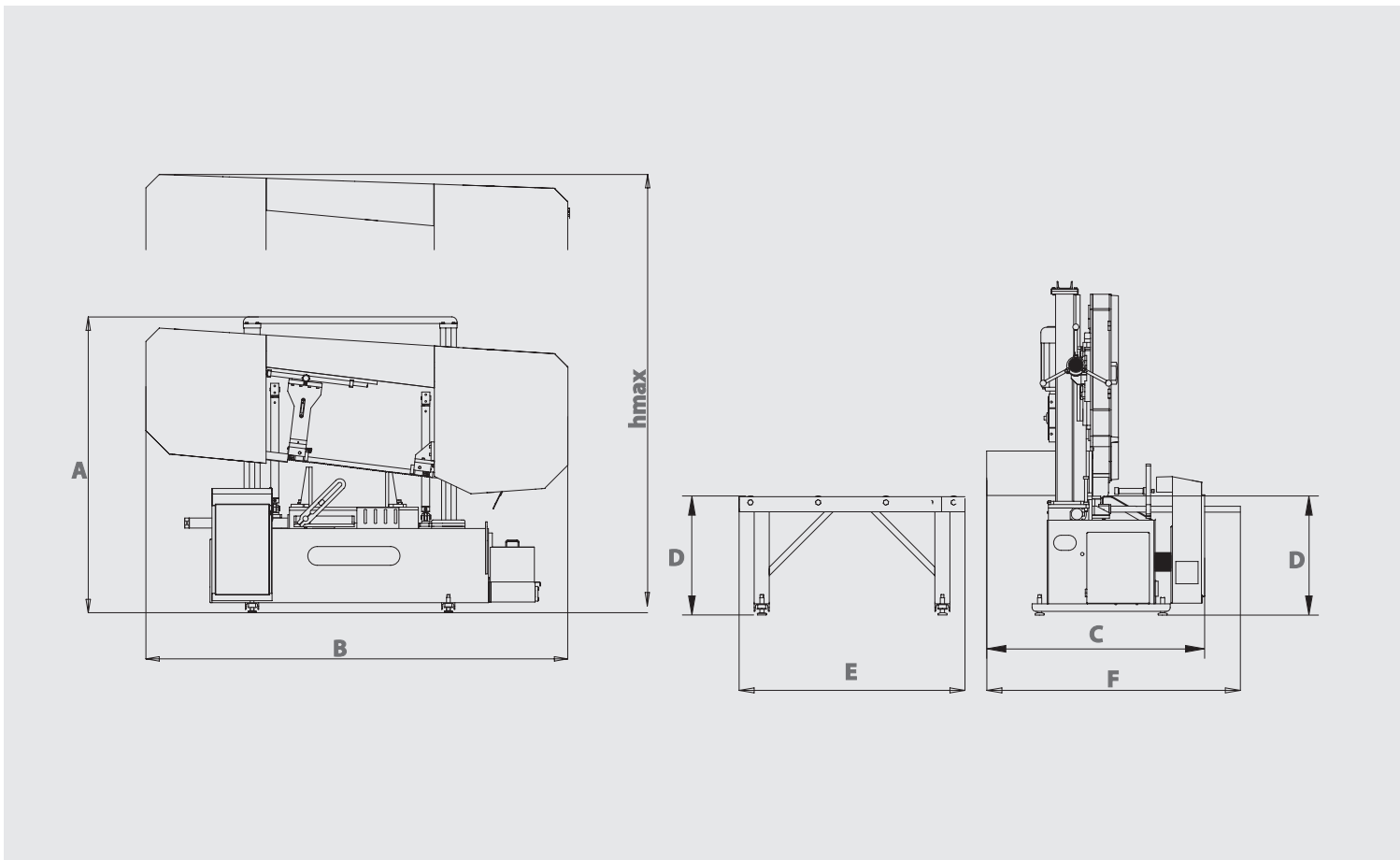

TEKNİK ÖZELLİKLER TECHNICAL FEATURES

A	2215 mm 87.20 inch	B	3200 mm 125.98 inch	C	1460 mm 57.48 inch	D	765 mm 30.12 inch	E	2000 mm 78.74 inch	F	1690 mm 66.54 inch	hmax	2410 mm 94.88 inch
---	-----------------------	---	------------------------	---	-----------------------	---	----------------------	---	-----------------------	---	-----------------------	------	-----------------------

Yarı Otomatik Semi Automatic	Şerit Ölçüsü Blade Dimension 41 x 1.3 x 6850 mm 1 1/2 x 0.050 x 249.6 inch	Şerit Motoru Blade Motor 4 kW - 1000 d/dk 5.36 hp - 1000 rpm	Sürücü Motor Feeding Motor Manuel Manual
Hidrolik Motor Hydraulic Pump Motor 1.1 kW - 1500 d/dk 1.46 hp - 1500 rpm	Soğutucu Motor Cooling Liquid Motor 0.12 kW - 3000 d/dk 0.16 hp - 3000 rpm	Voltaj Voltage 400 V 400 V	Maksimum Güç Maximum Power 5.22 kW 7 hp
Kesme Hızı Cutting Speed 15 m/dk - 49 ft/min 100 m/dk - 328 ft/min	Ağırlık Weight 2100 kg 4620 lbs	Malzeme Sıkma Sistemi Material Clamping System Hidrolik Hydraulic	Şerit Germe Sistemi Blade Tensioning System Hidromekanik Hydramechanic

90°	60°	45°	30°	0°	10°	45°	60°
Kesim Kapasitesi Cutting Capacity	Kesim Kapasitesi Cutting Capacity	●	■	■	■	■	■
550 mm 21.65 inch	600 mm 23.62 inch	370 mm 14.57 inch	370 x 370 mm 14.57 x 14.57 inch	460 mm 18.11 inch	460 x 460 mm 18.11 x 18.11 inch	550 mm 21.65 inch	550 x 550 mm 21.65 x 21.65 inch
		550 x 370 mm 21.65 x 14.57 inch	550 x 460 mm 21.65 x 18.11 inch	550 x 600 mm 21.65 x 23.62 inch			