

## **CSM 550x800 DM NC BANDSAW MACHINE**

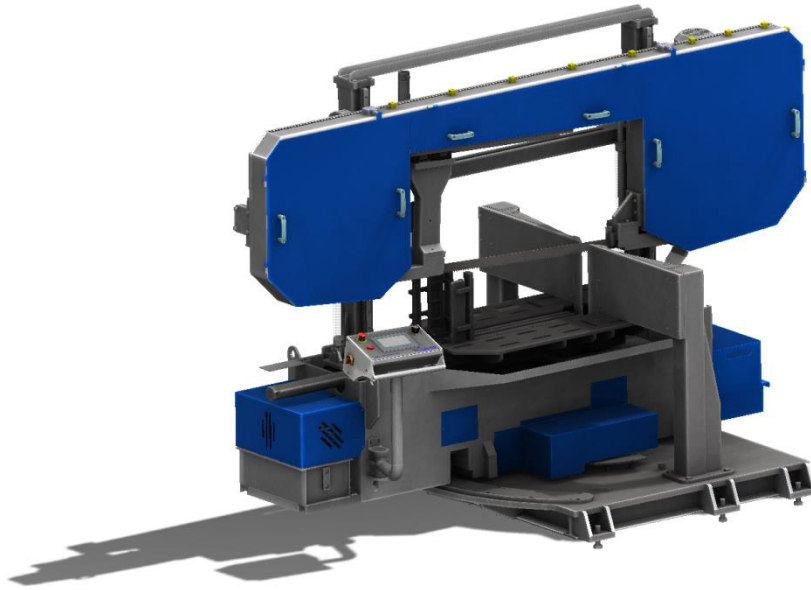

### **1-GENERAL SPECIFICATIONS**

- Touchscreen LCD
- Linear guiding column
- Blade linear guides
- Stepless blade speed setting
- Easily cleaning portable coolant reservoir and swarf bin
- Double mitre cut
- Automatic angle setting
- Precision head lowering speed
- After cutting finished automatic stop and hydraulic head lifting
- Hydraulic blade tension
- Hydraulic material clamping
- Adjustable material clamping pressure
- Steel material clamping and vices
- Coolant system from blade guides
- Steel centre housing.
- Blade breakage switch, phase protection relay.
- Cast iron blade pulleys.
- Electrical motor with thermal protection
- Board and blade cover security switches
- Bi-metal bandsaw blade
- Blade guiding twin bearings
- Single bearing guides blade top
- Adjustable blade guides and carbide guides
- Adjustable top limit switch
- Easy hydraulic system control by manometers
- Cooling liquid and hydraulic oil level indicators
- Bundle clamping

## 2- TECHNICAL SPECIFICATIONS

<b>CSM 550x800 DM NC</b>	<b>45</b>	<b>30</b>	<b>0</b>	<b>30</b>	<b>45</b>	<b>60</b>
<b>Circle</b>	500	550	550	550	500	300
<b>Square</b>	500x500	550x550	550x550	550x550	500x500	300x300
<b>Rectangle</b>	550x500	550x610	550x800	550x610	550x500	550x300

<b>Blade Dimensions: 54x1,6x7220</b>
<b>Blade Motor: 4 kw 1500 rpm</b>
<b>Hydraulic Motor: 1,1 kw 1500 rpm</b>
<b>Coolant Motor: 0,12 kw 2800 rpm</b>
<b>Voltage: 400 V</b>
<b>Max. Power: 5,97 kW</b>
<b>Blade Speed: 15-100</b>
<b>Weight: 4000 kg</b>